

# Precision Leveling

© Yong-Won Ahn / University of New Brunswick, Canada

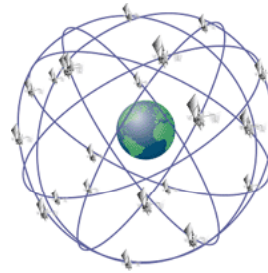
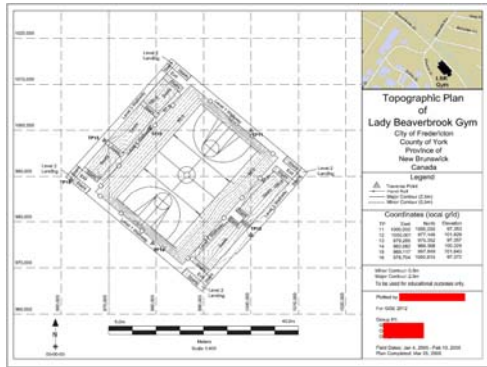

1/00

Yong-Won Ahn • Department of Geodesy and Geomatics Engineering • University of New Brunswick

# Leveling

## ◆ Techniques of Leveling

### ● One Setup

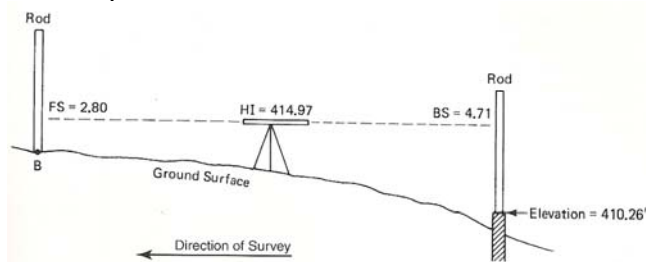

FIGURE 3.12 Leveling procedure: one setup.  
(Kavanagh, 2006)

Elev.BM(A)	= 410.26
BS (reading)	= 4.71 BS
HI	= 414.97 HI
FS at TBM(B)	= -2.80 FS
Elevation at TBM B	= 412.17

: setup almost midway between BS and FS in order to eliminate (or minimize) errors due to the curvature and refraction as well as the collimation

2/00

Yong-Won Ahn • Department of Geodesy and Geomatics Engineering • University of New Brunswick

# Leveling

## ◆ Techniques of Leveling

- More than one setup

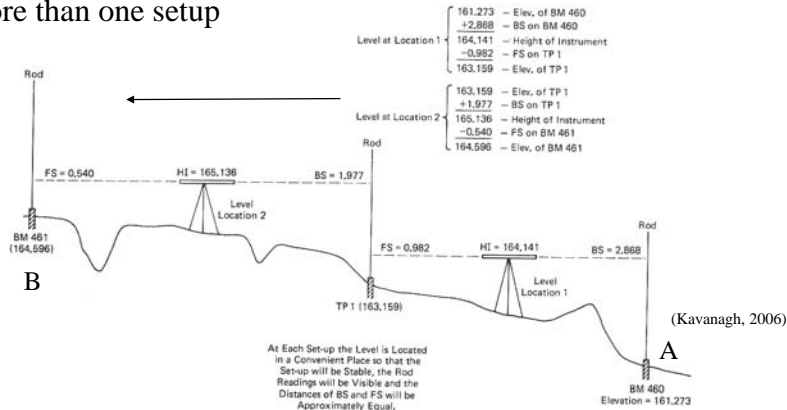

: after determined the height at B → return the survey to the point of start to close the loop → determine the accuracy and acceptability of the survey. Not within the limit → repeated

3/00

Yong-Won Ahn • Department of Geodesy and Geomatics Engineering • University of New Brunswick

# Leveling

## ◆ Techniques of Leveling

- Benchmark Leveling  
: vertical control surveys
- Profile and Cross-Section Leveling  
: road, sewer pipe line, channel etc.

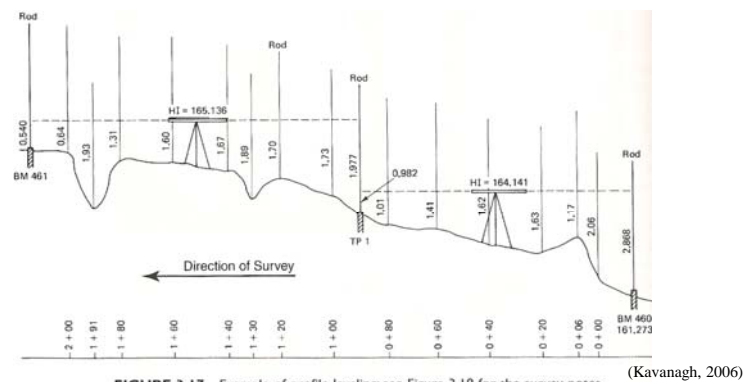

FIGURE 3.17 Example of profile leveling; see Figure 3.18 for the survey notes.

4/00

Yong-Won Ahn • Department of Geodesy and Geomatics Engineering • University of New Brunswick

# Leveling

## ◆ Practical Examples

1) Due to the big fence as seen from the right figure of PQ, you read your level rod in a reverse way from Q and got the readings of 0.85m FS (A), and 0.47m FS (B). When the elevation of A is 51.25m, then what is the elevation of point B.

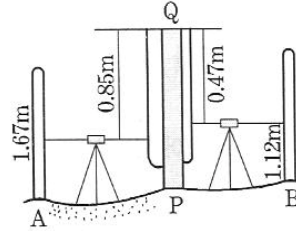

2) The survey points were on the ceiling of a tunnel, and you achieved the following values the same as right figure. When the elevation of A is 15.32m, then what is the elevation of point C?

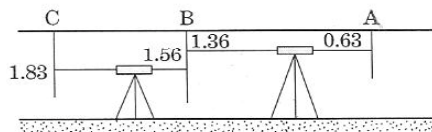

5/00

Yong-Won Ahn • Department of Geodesy and Geomatics Engineering • University of New Brunswick

# Leveling

## ◆ Techniques of Leveling

: move or wave the rod towards or away from the instrument → correct reading will be the lowest reading observed

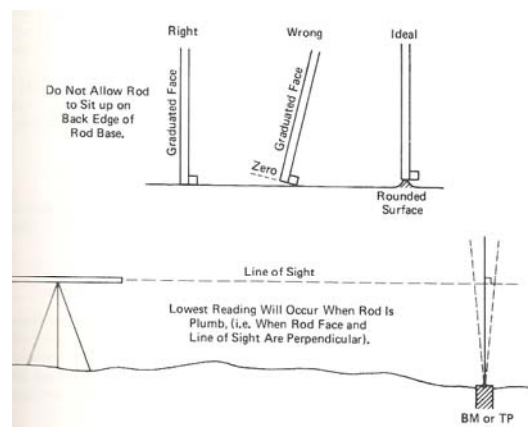

(Kavanagh, 2006)

6/00

Yong-Won Ahn • Department of Geodesy and Geomatics Engineering • University of New Brunswick

## Leveling

◆ **Expected Error due to plumbing error due to tilt**

$\theta$  : inclined angle (see figure)

$a'$  : rod reading

$oa - oa'$  : error due to the tilt

$$oa = oa' \cos \theta = oa' \left( 1 - 2 \sin^2 \frac{\theta}{2} \right) = oa' - 2oa' \sin^2 \frac{\theta}{2}$$

$$\therefore oa - oa' = -2oa' \sin^2 \frac{\theta}{2}$$

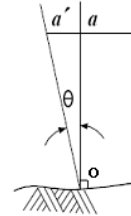

$\theta$  is very small angle  $\rightarrow$  expands it by Taylor Series (ignore the higher order than one)

$$\sin^2 \frac{\theta}{2} = \left( \sin \frac{\theta}{2} \right) \left( \sin \frac{\theta}{2} \right) \doteq \left( \frac{\theta}{2} \right) \left( \frac{\theta}{2} \right) = \frac{\theta^2}{4} \quad \sin \frac{\theta}{2} = \frac{\theta}{2} - \frac{\left( \frac{\theta}{2} \right)^3}{3!} + \dots$$

$$\therefore oa - oa' \approx -2oa' \frac{\theta^2}{4}$$

7/00

Yong-Won Ahn • Department of Geodesy and Geomatics Engineering • University of New Brunswick

## Leveling

◆ **Leveling Error due to curvature**

: Expected errors in case of curvature

$$R^2 + T^2 = (R + e_p)^2$$

$$e_p = (R^2 + T^2)^{1/2} - R$$

$$= R + \frac{T^2}{2R} - \frac{T^4}{8R^3} - R$$

$$e_p \cong \frac{T^2}{2R} \quad (T \ll R) \cong 0.0785 k^2$$

with  $k$  (km) from the point of tangency

0.0675  $k^2$  (with refraction)

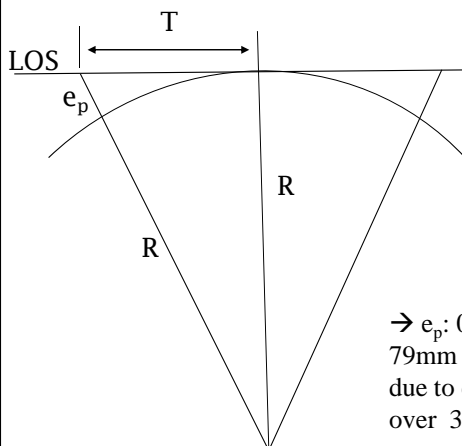

$\rightarrow e_p$ : 0.07mm over 30m, 1mm over 113m, 79mm over 1km.

due to curvature, and refraction  $\rightarrow e_p$ : 0.06mm over 30m, 1mm over 122m, 68mm over 1km.

(GGE1001 Lecture Note)

cf.)  $(a + b)^k = a^k + ka^{k-1}b + \frac{k(k-1)}{2!}a^{k-2}b^2 + \dots + b^k$  (from Binomial Theorem)

8/00

Yong-Won Ahn • Department of Geodesy and Geomatics Engineering • University of New Brunswick

# Leveling

## ◆ Leveling Accuracy

: If systematic errors are “properly” eliminated, the effect of remaining residual random errors in the height difference of a leveling line with  $n$  setups

$$\Delta h = \Delta h_1 + \Delta h_2 + \Delta h_3 + \Delta h_4 + \dots + \Delta h_n$$

: Corresponding errors can be given by the law of error propagation as

$$\sigma_{\Delta h}^2 = \sigma_{\Delta h_1}^2 + \sigma_{\Delta h_2}^2 + \sigma_{\Delta h_3}^2 + \sigma_{\Delta h_4}^2 + \dots + \sigma_{\Delta h_n}^2$$

$$\sigma_{\Delta h}^2 = n \cdot \sigma^2 \quad \text{or} \quad \sigma_{\Delta h} = \sigma \cdot \sqrt{n}$$

(if  $\sigma_{\Delta h_i} = \sigma, \quad i=1,2,3,\dots,n$ )

: Using the standard deviation of 1km as a reference, we can get:

$$\sigma_{\Delta h} = \sigma \cdot \sqrt{n} = \sigma_{(1km)} \cdot \sqrt{S_{(km)}} \quad \text{where } \sigma_{(1km)} \text{ is the order of } 2\sim 5\text{mm}$$

9/00

Yong-Won Ahn • Department of Geodesy and Geomatics Engineering • University of New Brunswick

# Leveling Classification

(Kavanagh, 2006)

**Table 3.1** NATIONAL OCEAN SURVEY, U.S. COAST AND GEODETIC SURVEYS: CLASSIFICATION, STANDARDS OF ACCURACY, AND GENERAL SPECIFICATIONS FOR VERTICAL CONTROL

	$\max : (3 \sim 5\text{mm}) \cdot \sqrt{S_{(km)}}$ → First Order	$6\text{mm} \cdot \sqrt{S_{(km)}}$ Second Order	$8\text{mm} \cdot \sqrt{S_{(km)}}$	$12\text{mm} \cdot \sqrt{S_{(km)}}$
Classification	Class I, Class II	Class I	Class II	Third Order
<i>Principal uses:</i>				
Minimum standards; higher accuracies may be used for special purposes	Basic framework of the National Network and of metropolitan area control Extensive engineering projects Regional crustal movement investigations Determining geopotential values	Secondary control of the National Network and of metropolitan area control Large engineering projects Local crustal movement and subsidence investigations Support for lower-order control	Control densification, usually adjusted to the National Network. Local engineering projects Topographic mapping Studies of rapid subsidence Support for local surveys	Miscellaneous local control; may not be adjusted to the National Network. Small engineering projects Small-scale topographic mapping Drainage studied and gradient establishment in mountainous areas
<i>Recommended spacing of lines:</i>				
National Network	Net A: 100 to 300 km, Class I Net B: 50 to 100 km, Class II	Secondary network: 20 to 50 km	Area control: 10 to 25 km	As needed
Metropolitan control	2 to 8 km	0.5 to 1 km	As needed	As needed
Other purposes	As needed	As needed	As needed	As needed
Spacing of marks along lines	1 to 3 km	1 to 3 km	Not more than 3 km	Not more than 3 km
Gravity requirement*	$0.20 \times 10^{-3}$ gpu	—	—	—
<i>Instrument standards</i>	Automatic or tilting levels with parallel plate micrometers; invar scale rods	Automatic or tilting levels with optical micrometers or three-wire levels; invar scale rods	Geodetic levels and invar scale rods	Geodetic levels and rods
<i>Field procedures</i>	Double-run; forward and backward, each section	Double-run; forward and backward, each section	Double- or single-run	Double- or single-run
Section length	1 to 2 km	1 to 2 km	1 to 3 km for double-run	1 to 3 km for double-run
Maximum length of sight	50 m Class I; 60 m Class II	60 m	70 m	90 m

## Errors in Leveling

### ◆ Example of a Level Loop

ex) You completed the following level loops (see figure and table). When each loop must be closed within  $1.0\text{cm}\sqrt{S(\text{km})}$ , which leg number should be re-measured? Solution)

leg no.	hgt diff.	distance
1	+2.474m	4.1km
2	-1.250m	2.2km
3	-1.241m	2.4km
4	-2.233m	6.0km
5	+3.117m	3.6km
6	-2.115m	4.0km
7	-0.378m	2.2km
8	-3.094m	2.3km
9	2.822m	3.5km

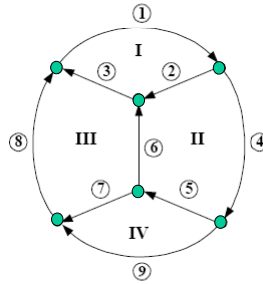

11/00

*Yong-Won Ahn • Department of Geodesy and Geomatics Engineering • University of New Brunswick*

## Errors in Leveling

### ◆ Random Errors

- **Uncertainty in cross hair setting due to air movement**
  - work on overcast days
  - work in morning or evening on hot days
- **Sinking of Rods**
  - carefully place ground plates
  - avoid soft ground
- **Unequal distance in backsight and foresight (earth curvature)**
  - use equal sight distance, e.g. using stadia or pacing

12/00

*Yong-Won Ahn • Department of Geodesy and Geomatics Engineering • University of New Brunswick*

## Errors in Leveling

### ◆ Systematic Errors

- **One sided reading errors (observer specific)**
  - use parallel plate micrometer
- **Scale and offset errors of rod graduation**
  - frequent rod calibration
- **Inclined rods**
  - frequent check of rod levels
- **Temperature influence in leveling instrument**
  - avoid rapid temperature changes
  - protect the instrument from direct sun light
  - provide time for instrument to reach field temperature (1 min per 1 deg. Celcius)

13/00

Yong-Won Ahn • Department of Geodesy and Geomatics Engineering • University of New Brunswick

## Errors in Leveling

### ◆ Systematic Errors (cont')

- **Sinking of instrument**
  - setting up on a solid ground
  - use double scale rods in the sequence
- **Refraction**
  - LOS at least 0.5m above ground
  - avoid large temperature gradient
  - apply refraction models
- **Magnetic field of the earth**
  - was a problem in older compensator levels

14/00

Yong-Won Ahn • Department of Geodesy and Geomatics Engineering • University of New Brunswick

# Leveling

## ◆ Types of surveying level

● Automatic Level *ex) NIKON AE-7, LEICA NA720, LEICA WILD NA20*

: employs a gravity-referenced prism or mirror compensator to orient the line of sight (line of collimation) automatically

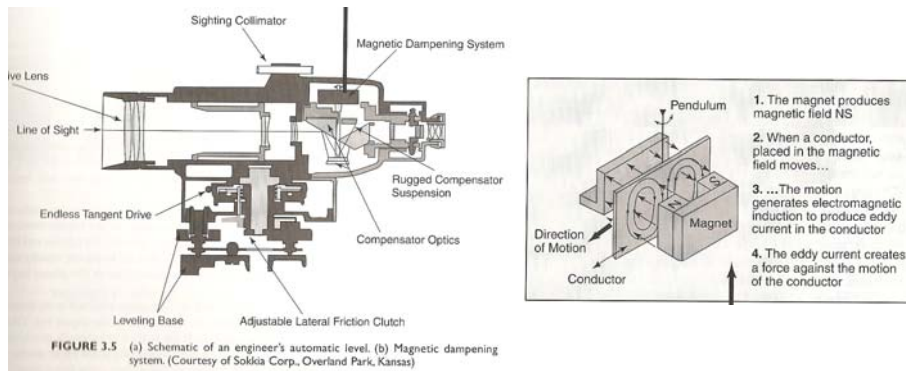

(Kavanagh, 2006)

15/00

Yong-Won Ahn • Department of Geodesy and Geomatics Engineering • University of New Brunswick

# Parallel Plate Micrometer

## ◆ Precision Reading with PPM

- : a parallel plate, placed in front of the objective lens, which can be rotated around a horizontal axis to the collimation axis
- : helps in obtaining precise rod reading, instead of estimating it
- : when rotating the micrometer drum, the parallel is rotated causing the collimation axis to be shifted up or down
- : a reading is taken when the horizontal line of the cross hair (flat wedge) sets on a graduation line
- : rod and micrometer readings are to be added to obtain the final reading

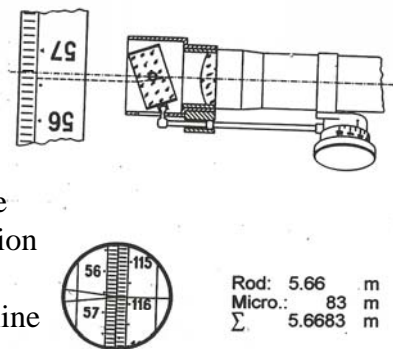

16/00

Yong-Won Ahn • Department of Geodesy and Geomatics Engineering • University of New Brunswick

## Parallel Plate Micrometer

### ◆ Precision Reading



Measuring range:  $\pm 5\text{mm}/100$  divisions  
 (total: 10mm reading)  
 Minimum reading: 0.1mm/1 division  
 Measuring accuracy: within 0.05mm

17/00

Yong-Won Ahn • Department of Geodesy and Geomatics Engineering • University of New Brunswick

## Parallel Plate Micrometer



Normal Auto Level  
(NIKON AE-7)

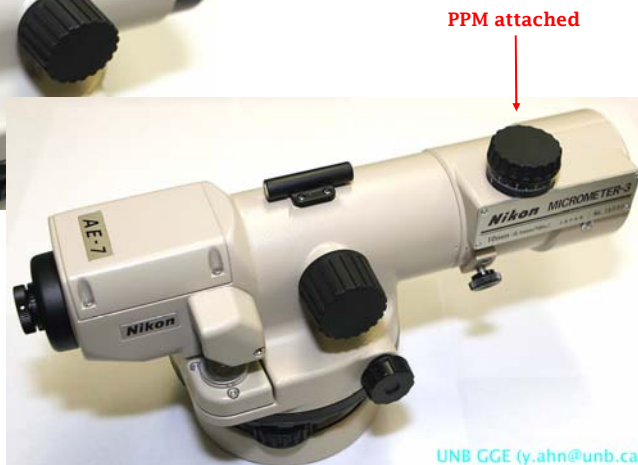

Normal Auto Level with PPM (Plate Parallel Micrometer)

18/00

Yong-Won Ahn • Department of Geodesy and Geomatics Engineering • University of New Brunswick

## Parallel Plate Micrometer

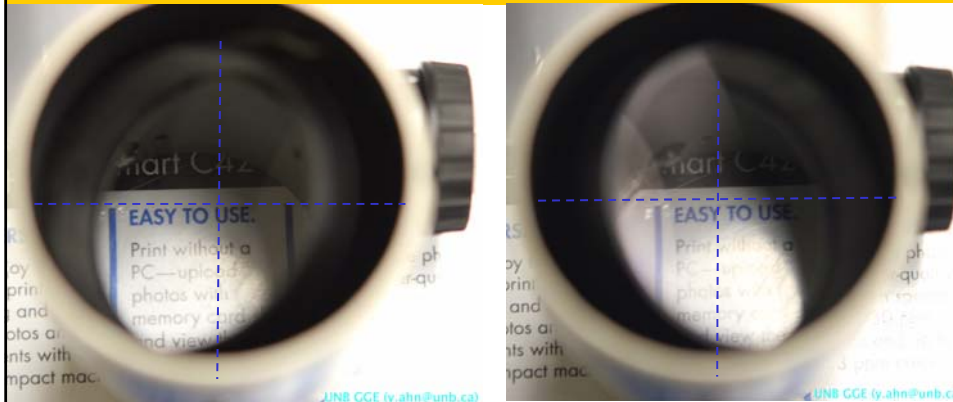

(PPM with “left end” angle of the mirror)

(PPM with “right end” angle of the mirror)

**Just Compare the images to how they are different each other when you move the mirror.**

**(In the field work, the mirror must be moved in the vertical way, not left or right as shown above. This is just for illustration)**

19/00

Yong-Won Ahn • Department of Geodesy and Geomatics Engineering • University of New Brunswick

## Parallel Plate Micrometer

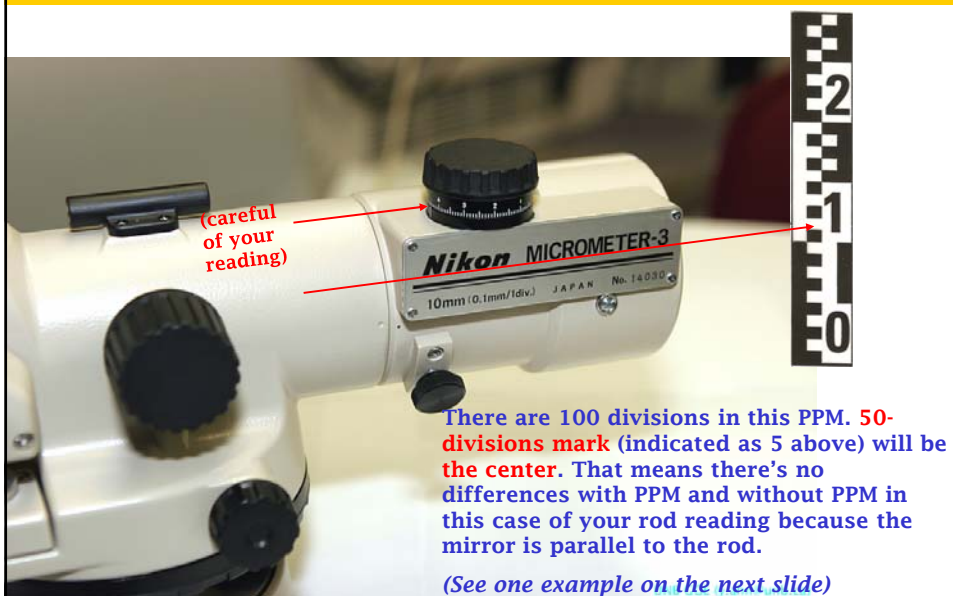

**There are 100 divisions in this PPM. 50-divisions mark (indicated as 5 above) will be the center.** That means there's no differences with PPM and without PPM in this case of your rod reading because the mirror is parallel to the rod.

*(See one example on the next slide)*

20/00

Yong-Won Ahn • Department of Geodesy and Geomatics Engineering • University of New Brunswick

## Example of PPM reading

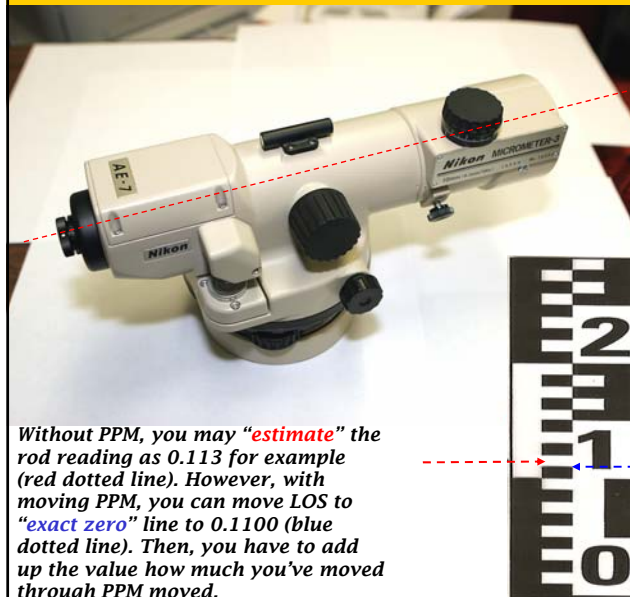

Without PPM, you may “*estimate*” the rod reading as 0.113 for example (red dotted line). However, with moving PPM, you can move LOS to “*exact zero*” line to 0.1100 (blue dotted line). Then, you have to add up the value how much you’ve moved through PPM moved.



Example)

+43 divisions are moved from your original (centered and aligned mirror) reading through PPM in order to make align the centered value to 0.1100.

Then,  $43 \times 0.1\text{mm} = 4.3\text{mm}$  moved. So, add this value to the 0.1100.

Answer:  
 $0.1100\text{m} + 4.3\text{mm} = 0.1143\text{m}$

21/00

Yong-Won Ahn • Department of Geodesy and Geomatics Engineering • University of New Brunswick

## Leveling

### ◆ Error due to malfunctioning compensator

- : When the bubble is centered (or near so), the compensator takes over and maintains a horizontal line of sight, even if the telescope is slightly tilted.
- : Needs to be very careful, though, when the compensator is broken.

[Q] How to check whether the compensator is working properly or not?

(tapping the end of telescope or slight turning one of the level screws → being slight off from horizontal. If it’s working fine, the cross hair appears to deflect momentarily before returning to its original rod reading. → Constant checking is important.

(Kavanagh, 2006)

22/00

Yong-Won Ahn • Department of Geodesy and Geomatics Engineering • University of New Brunswick

## Leveling

### ◆ Digital Levels

- : is automatic level with bar-coded rod, but has a digital electronic image processor that uses CCD for determining heights and distances
- : At the press of the button, image of the bar code (in the level's field of view) is generated
- : The generated image is then compared with the stored (reference) pattern inside the level.
- : When a match is found, the reading is taken
- : Distance of the rod is also measured, based on the levels field of view



(TOPCON Digital Level)  
(accuracy: 0.4mm with invar staff in 1km)

23/00

Yong-Won Ahn • Department of Geodesy and Geomatics Engineering • University of New Brunswick

## Leveling

### ◆ Digital Levels



(Trimble's Digital Level, DiNi)  
(accuracy: 0.2mm in 1km double run with invar staff)



(SOKKIA SDL30)  
(accuracy: 0.6mm in 1km double run with invar Bar-coded staff)

: accuracy depending on the rod used (invar is more precise than fiberglass type)

24/00

Yong-Won Ahn • Department of Geodesy and Geomatics Engineering • University of New Brunswick

## Leveling

### ◆ Bar Coded Rod

: The part of the staff code viewed down the telescope is imaged on the photodiode and converted into a digital measurement signal, which is then correlated with the reference signal stored in the microprocessor. This reference signal relates to the stored image of the whole staff scale.

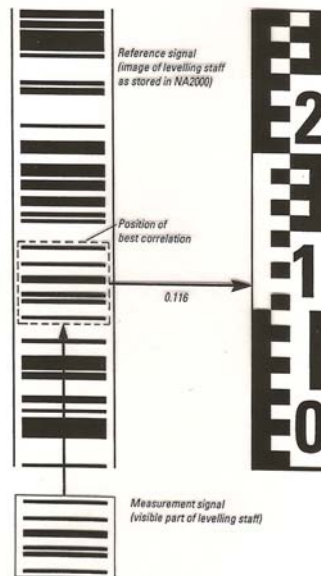

25/00

Yong-Won Ahn • Department of Geodesy and Geomatics Engineering • University of New Brunswick

## Leveling

### ◆ Laser Level

- : Automatic level with a rotating laser beam to establish a horizontal (or vertical) reference plane
- : A detection device is used sometimes to capture the rotating laser beam
- : Used mainly for construction control
  - outdoor applications include site grading, foundation work, pipeline construction etc.
  - indoor applications include installation of false ceilings, floor leveling etc.
- : Requires only one person to operate
- : Most instruments are designed in such a way that if the unit is tilted beyond its self-leveling range, the rotation and the laser beam stop automatically
- : Accuracy is the order of 2mm at 30m
- : Diameter covered is up to 600m (LP30)



(SOKKIA LP31 Laser Level)  
(accuracy:  $\pm 2.25$ mm in 30m for LP31,  $\pm 1.5$ mm for LP30)

26/00

Yong-Won Ahn • Department of Geodesy and Geomatics Engineering • University of New Brunswick

# Leveling

## ◆ Tilting level

- Tilting Level: most obsolete one

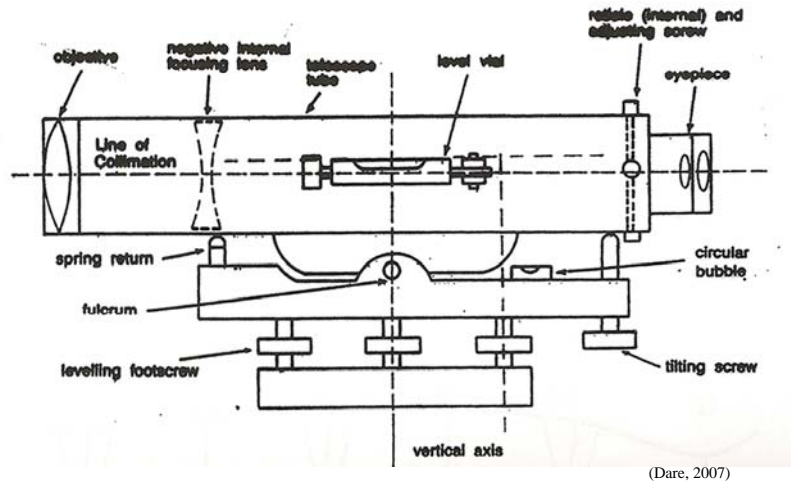

27/00

Yong-Won Ahn • Department of Geodesy and Geomatics Engineering • University of New Brunswick